

Powerkit

Electronic Water Boiler



PEWB-5S



PEWB-5W



PEWB-5B



Powerkit is a fully auto-electronic Water Boiler with an outstanding and smart outlook design. 90°C to 98°C hot water is supplying continuously after the quick initial boil. And water dispensing is just as easy as a touch or press on the tap.

It's elegant & durable design offers the ideal option for hot water provision in offices, cafes, canteens, chain store and restaurant or even at home.

Features

1. Stainless steel interior and exterior ensures high durability while giving a smart looking design.
2. Three optional finishing colors (black, white and original stainless steel color) to fit different location use.
3. Micro-computerized control system to automate and monitor water filling, water heating and water temperature. Dispensing water is keeping between 90°C and 98°C. Protection from overheating, overflow and water shortage allows a safeguarded operation.
4. Large LCD panel showing water temperature, ready-to-drink indication and some necessary alerting signals enables user-friendly operation.
5. Unique series of PEWB-5 provides intelligent water pouring.
6. Series of PEWB-10 and PEWB-30 are added with anti-dripping faucet to give a safer operating environment.



PEWB-10W



PEWB-10B



PEWB-10S



PEWB-30S



PEWB-30B



PEWB-30W

Powerkit

Electronic Water Boiler

PEWB-5

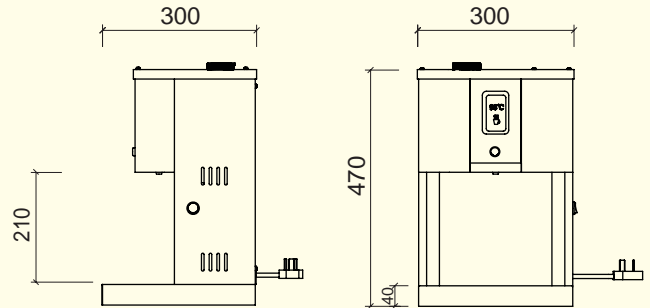

PEWB-10

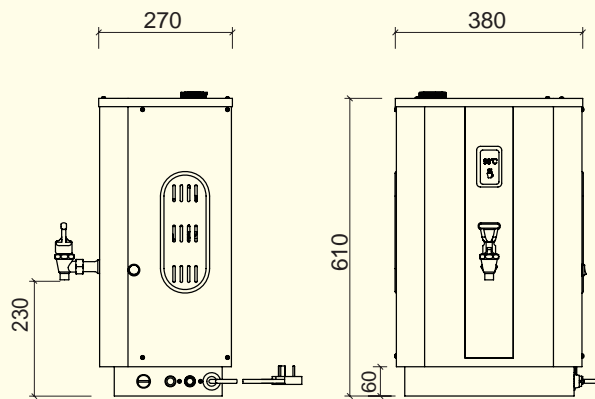

PEWB-30

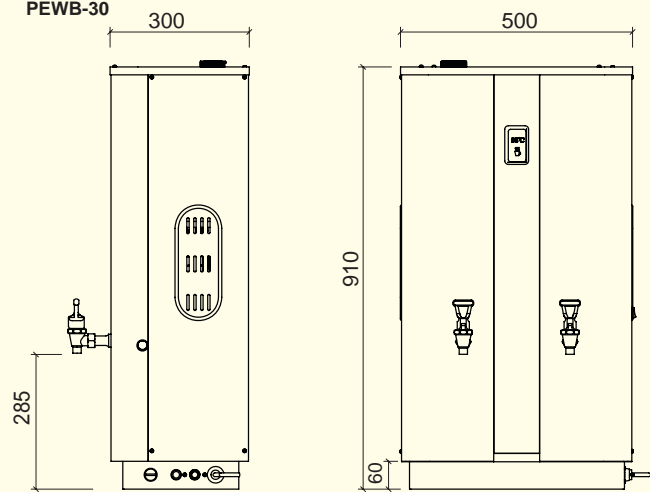

Specifications of Electronic Water Boiler

| Model | PEWB-5S PEWB-5B PEWB-5W | PEWB-10S PEWB-10B PEWB-10W | PEWB-30S PEWB-30B PEWB-30W |
|------------------------------|-------------------------------|----------------------------------|----------------------------------|
| Width x Depth x Hight (mm) | 300 x 300 x 470 | 380 x 270 x 610 | 500 x 300 x 910 |
| Voltage | 220V/1ph/50-60Hz | 220V/1ph/50-60Hz | 380V/3ph/50-60Hz |
| Loading (Kw) | 2.8 | 2.8 | 9 |
| Water inlet pipe (mm) | Ø9 | Ø13 | Ø13 |
| Water Pressure (Bar) | 3 ~ 5 | 5 ~ 8 | 5 ~ 8 |
| Faucet (mm) | Ø9 | Ø13 | 2 x Ø13 |
| Hot Water supply (Litre/hr.) | 35.5 | 60 | 180 |
| Net / Gross Wt. (kgs) | 11 / 14 | 15 / 19 | 27 / 32 |

Specifications of Water Boiler Stand

| Model | / | PWBS-10 | PWBS-30 |
|----------------------------|---|-----------------|-----------------|
| Width x Depth x Hight (mm) | / | 410 x 500 x 840 | 550 x 530 x 840 |
| Drainage Pipe (mm) | / | Ø32 | Ø32 |
| Net / Gross Wt. (kgs) | / | 14 / 17 | 19 / 24 |

All suffix with S = Stainless Steel, B = Black colour, W = White colour

Optional adjustable water pressure valve.

Water filter is highly recommended to install before the water inlet pipe of all models.

Hong Kong Office:

Flat C, 25/F., Block 1, Golden Dragon Industrial Centre,
152-160 Tai Lin Pai Road, Kwai Chung, N.T. Hong Kong

Tel. : (852) 2371 2862

Fax.: (852) 2371 2867

e-mail: profit@profitind.com website: www.profitind.com