

# Powerkit

## Electric Fryer & Griddle



### Start-up Time for Electric Fryer

Oil Temp. (°C)	Time (minutes)
100	4.5
150	8
200	12

### Start-up Time for Electric Griddle

Griddle Surface Temp. (°C)	Time (minutes)
150	8
200	12
250	15
300	20

Electric Fryer and Griddle are well-suited for all kitchens of western, Chinese restaurants, fast-food chain store and canteens. Stainless steel exterior body with heavy duty heating element and temperature control function ensure high efficiency and easy operation.

### Features

1. High durable stainless steel interior and exterior with grand and smart looking design.
2. Electric fryer – Electronic thermostat providing reliable and accurate temperature control to prevent overheating. Together with Overheat Reset function, a safer cooking environment is guaranteed. Quick start up time and large wire basket allow efficient frying with higher capacity. Removable stainless steel tank with pull handles make it easier for operators to lift up for cleaning purpose.
3. Electric griddle – Enhanced insulation underneath the heating elements highly increases the heat efficiency. Full spatula-width grease trough for easy cleaning. Thermostats controlled griddle surface temperature allows even heat distribution for different cooking requirement.

# Powerkit

## Electric Fryer & Griddle

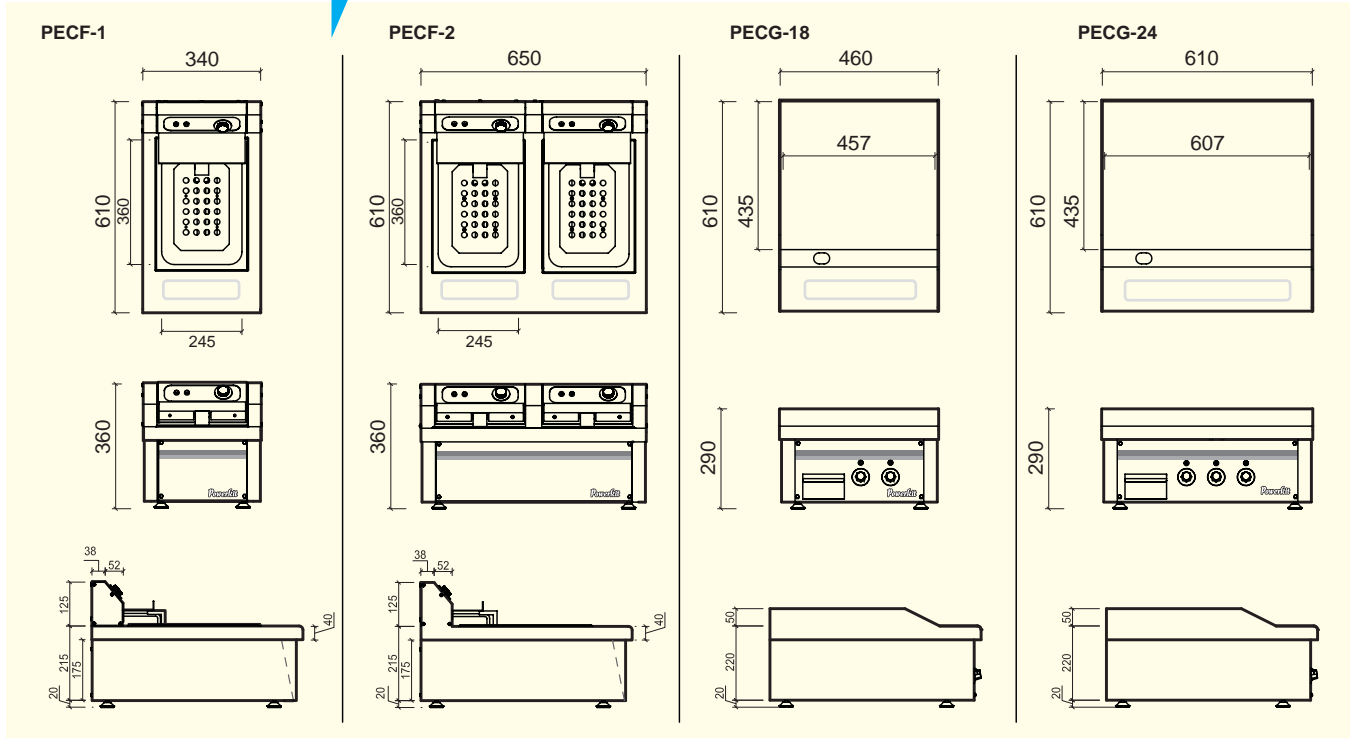

### Specifications of Electric Fryer

Model	PECF-1	PECF-2
<b>Specification</b>		
Width x Depth x Height (mm)	340 x 610 x 360	650 x 610 x 360
Voltage	220V/1ph/50-60Hz	**220V/1ph/50-60Hz (2 units)
Loading (Kw)	6	6 x 2
Net / Gross Wt. (kgs)	13 / 18	24 / 30
<b>Oil tank</b>		
Width x Depth x Height (mm)	245 x 360 x 190	245 x 360 x 190 x (2 tanks)
Capacity (Litre)	11	11 x (2 tanks)
<b>Wire basket</b>		
Width x Depth x Height (mm)	215 x 260 x 140	215 x 260 x 140
Number of basket	1	2

\*\*Option for ONE unit of 380V/2ph/50-60Hz

### Specifications of Electric Griddle

Model	PEGG-18	PEGG-24
<b>Specification</b>		
Width x Depth x Height (mm)	460 x 610 x 290	610 x 610 x 290
Voltage	220V/1ph/50-60Hz	380V/3ph/50-60Hz
Loading (Kw)	6	9
Net / Gross Wt. (kgs)	37 / 42	55 / 60
<b>Griddle surface</b>		
Width x Depth x Height (mm)	457 x 435 x 15	607 x 435 x 15

#### Hong Kong Office:

Flat C, 25/F., Block 1, Golden Dragon Industrial Centre,  
152-160 Tai Lin Pai Road, Kwai Chung, N.T. Hong Kong  
Tel. : (852) 2371 2862 Fax.: (852) 2371 2867  
e-mail: profit@profitind.com website: www.profitind.com