



http://www.profitind.com

**POWER FLAME**

**Steamer (Dim Sum)**



FSE-1AB-GN2-CE

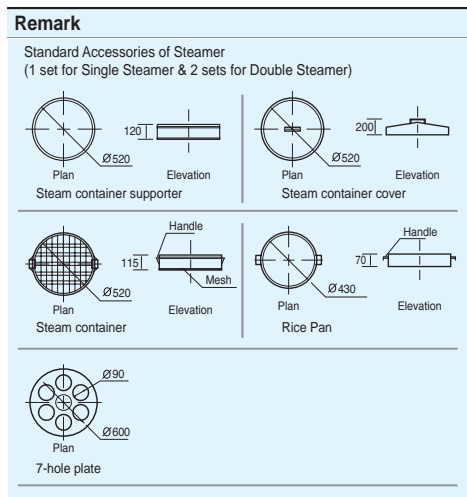
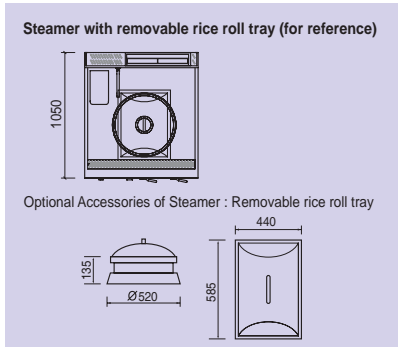
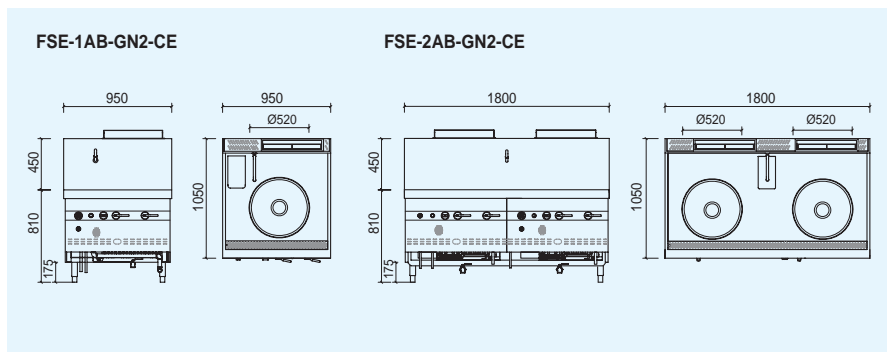

**Fuel suit for:** Town Gas, Natural Gas, Butane / Propane (L.P. Gas) (must specify gas type before ordering).

If any of these units will be installed in area with hard water supply, water softener shall be installed before water inlet of the unit to avoid any damages may occur to the heating chamber.

Daily cleaning & water drain from heat exchange chamber after daily use.

**Specifications of Steamer**

	Single Steamer	Double Steamer
Model	FSE-1AB-GN2-CE	FSE-2AB-GN2-CE

**Dimensions (mm)**

Width x Depth x Height: 950 x 1050 x (810+450) | 1800 x 1050 x (810+450)

Qty of Burner(s): 4 | 2 x 4

**Operating Pressure (mbar) / Heat input kW (BTU / hr.)**

Gas Type	Operating Pressure (mbar)	Heat input kW (BTU / hr.)	Qty
G30 Butane / G31 Propane (L.P. Gas)	I1a	8mbar	45 (153560)
	I3+(28-30/37)	28-30 / 37mbar	45 (153560)
	I3B/P(30)	30mbar	
	I3B/P(37)	37mbar	
I3B/P(50)	50mbar	2 x 45 (2 x 153560)	
G20 & G25 (Natural Gas)	I2E ; I2E+ ; I2H		20mbar
	I2L	25mbar	2 x 45 (2 x 153560)

**Fuel Pipe Connection (mm)**

Town Gas	Ø25	2 x Ø25
Butane / Propane (L.P. Gas)	Ø25	2 x Ø25
Natural Gas	Ø25	2 x Ø25

**Water inlet / Drainage Pipe (mm)**

Water inlet	Ø15	Ø15
Drain	Ø38	Ø38

<b>Net / Gross Wt. (kgs)</b>	170 / 270	340 / 500
------------------------------	-----------	-----------